

## » Description

The EDR series safety limit switches conform to EN 50047 and have been developed to provide a range of options including plastic cases in various sizes, a choice of snap acting, slow break/make with 2 contact configurations and a choice of actuator heads.

The EDR series offers the option of rotating the head in 90 ° increments before installation to allow ease of mounting.

Highly limit switches can be used in other applications other than guard doors, for example on moving machine beds, crane arms, lifts, elevators, etc.

Operation of these limit switches is achieved by the sliding action of the guard or other moving object deflecting the plunger or lever. For safety applications it is important that upon actuation, the guard or other moving objects should not pass completely over the switch and allow the plunger or lever to return to its original position.

## » Features

- Conforms to EN (TUV) standards corresponding to the CE marking.
- Positive opening operation of NC (Normally Closed) contacts conforming to IEC /EN 60947-5-1
- Double insulation makes ground terminal unnecessary (Bears □ marking)
- Wide standard operating temperature range: -25°C to 80°C
- Full range of actuator heads and levers suitable for safety applications
- Sealing up to IP 67
- Wide switch variations, (Snap action and slow action basic switches)
- International conduit sizes



## » Specifications

Electrical Characteristics		
Rating	TUV (EN60947-5-1 ), UKCA(BS EN60947-5-1) , CCC (GB 14048.5)	
	Utilization category	AC-15
	Rated operating current (Ie)	3A
	Rated operating voltage (Ue)	240V
	UL (UL508) AC-15 A600	
	Contact Type	1: 1NC/1NO Slow Action BBM
		2: 2NC Slow Action
		6: 1NC/1NO Snap Action Zb
	UL (UL508) AC-15 A300	
Contact Type	4: 2NC/1NO Slow Action BBM	
	5: 3NC Slow Action	
UL (UL508) AC-15 B600		
Contact Type	3: 1NC/1NO Snap Action Za	

Electrical Characteristics	
Contact resistance	Initial value 25mΩ max.
Min Current	5VDC 5mA
Insulation Voltage	600V
Thermal Current (Ith)	10A
Insulation Resistance	100MΩ Min (DC 500V)
Protection Against Electric Shock	Class II (double insulation).
Dielectric Strength	2,500V 50/60Hz for 1 minute.
Rated Frequency	50/60 Hz.
Pollution Degree	3

Mechanical Characteristics	
Electrical durability	150,000 Cycles Min.
Mechanical durability	1,000,000 Cycles Min.
Vibration durability	IEC 68-2-6,10-55Hz±1 HZ,Excursion: 0.35mm,1 octave/min.
Shock durability	300 m/s <sup>2</sup> min.
Max Switching Speed	250mm/s.

IEC 60947-5-1/EN 60947-5-1									
Designation & Utilization Category		Rated operational current Ie (A) at rated operational voltage Ue						VA rating	
		120V	240V	380V	480V	500V	600V	Make	Break
AC-15	A600	6	3	1.9	1.5	1.4	1.2	7200	720
AC-15	A300	6	3	-	-	-	-	7200	720
AC-15	B600	3	1.5	-	-	-	-	3600	360

Climatic Characteristics	
Degree of Protection	IP67
Operating Humidity	95% max. (for 5°C to 40°C)
Operating Temperature	-25°C ~ +80°C

## » Structure description

### Metal Lever Setting

Grooves which engage the lever every 18° are cut in the operation indicator disk to prevent the lever from slipping against the rotary shaft.

### Contact Block

Has a positive opening mechanism separating the contacts when the contacts are welded.

### Cover

The cover, with a hinge on its lower part, can be opened by removing the screw of the cover, which ensures ease of maintenance and wiring.

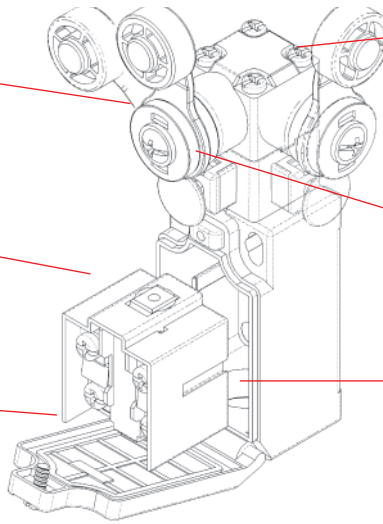

### Head

With roller lever models, the direction of the switch head can be adjusted to any of the four directions by loosening the roller lever switch screws at the four corners of the head.

### Reset Head

The direction of the reset head can be adjusted to any of the four directions.

### Conduit

Wide switch variations.  
PG13.5 PG11  
M16 M20  
1/2-14NPT

## » Product Selection

EDR-□-□-□

1 2 3

### 1.THREAD DIMENSION OF LEAD EXIT

1: PG13.5(S)

2: 1/2NPT(C)

4: PG11(O)

5: M16(C)

6: M20(O)

7: Connector(C)

\*(s):standard (o):option (c): customization

M12 Connector pin arrangement

①: 11  
②: 21/23  
③: 12  
④: 22/24

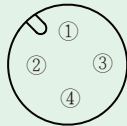

OPERATION DIAGRAMS

### 3.HEAD AND ACTUATOR

20: Roller arm type

21: Adjustable roller arm type (standard roller)

25: Rod lever type

27: Adjustable roller arm type (Rubber roller)

31: Push plunger type

32: Roller plunger type

62: Roller lever type

63: One-Way roller arm lever type

### 2.CONTACT TYPES

1: 1NC/1NO SLOW ACTION (BBM)(S)

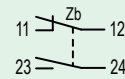

2: 2NC SLOW ACTION(O)

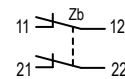

3: 1NC/1NO SNAP ACTION(C)

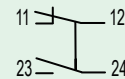

4: 2NC/1NO SLOW ACTION

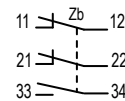

5: 3NC SLOW ACTION

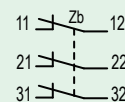

6: 1NC/1NO SNAP ACTION(Zb)(C)

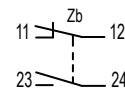

## » Operating Characteristics

### Actuator Type EDR-□-□-20 Roller Arm

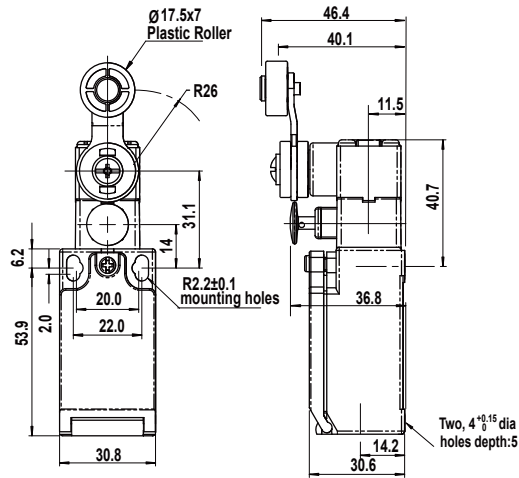

Operating characteristics	Model	EDR-□-1-20	EDR-□-3-20	EDR-□-2-20	EDR-□-6-20
		EDR-□-4-20		EDR-□-5-20	
Operating force	OF max.	6.5 N	5.3 N	6.5 N	5.0 N
Release force	RF min.	0.5 N	0.5 N	0.5 N	0.5 N
Pretravel	PT (NC)	25°~35°	23°~33°	25°~35°	18°~27°
	PT2 (NO)※1	(40°)	-	-	-
Overtravel	OT min.	40°	40°	40°	40°
Movement differential	MD max.	-	20°	-	14°
Total travel	TT※1	(80°)	(80°)	(80°)	(80°)
Positive Opening※2	Travel min.	45°	45°	45°	45°
	Force min.	19 N	19 N	19 N	19 N

\*1 Reference value

### Actuator Type EDR-□-□-21 Adjustable Roller

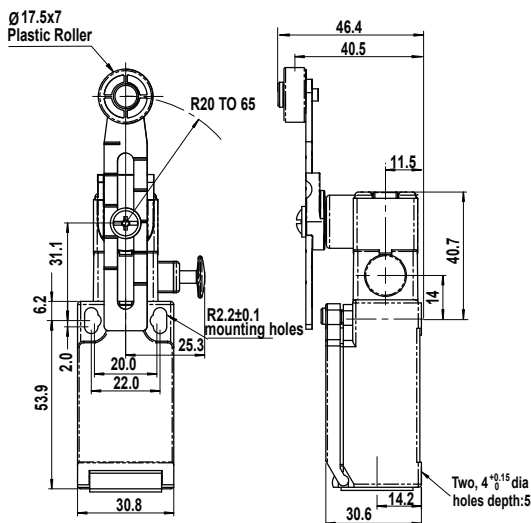

Operating characteristics	Model	EDR-□-1-21	EDR-□-3-21	EDR-□-2-21	EDR-□-6-21
		EDR-□-4-21		EDR-□-5-21	
Operating force	OF max.	5.2 N	4.5 N	5.2 N	4.5 N
Release force	RF min.	0.4 N	0.4 N	0.4 N	0.4 N
Pretravel	PT (NC)	25°~35°	23°~33°	25°~35°	18°~27°
	PT2 (NO)※1	(40°)	-	-	-
Overtravel	OT min.	40°	40°	40°	40°
Movement differential	MD max.	-	20°	-	14°
Total travel	TT※1.	(80°)	(80°)	(80°)	(80°)
Positive Opening	Travel min.	45°	45°	45°	45°
	Force min.	19 N	19 N	19 N	19 N

\*1 Reference value

### Actuator Type EDR-□-□-25 Rod Lever

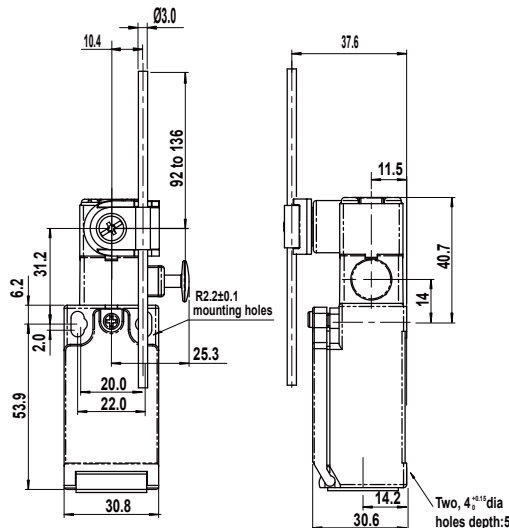

Operating characteristics	Model	EDR-□-1-25	EDR-□-3-25	EDR-□-2-25	EDR-□-6-25
		EDR-□-4-25		EDR-□-5-25	
Operating force	OF max.	1.8 N	1.8 N	1.8 N	1.8 N
Release force	RF min.	0.5 N	0.5 N	0.5 N	0.5 N
Pretravel	PT (NC)	25°~35°	23°~33°	25°~35°	18°~27°
	PT2 (NO)※1	(40°)	-	-	-
Overtravel	OT min.	40°	40°	40°	40°
Movement differential	MD max.	-	20°	-	14°
Total travel	TT※1	(80°)	(80°)	(80°)	(80°)
Positive Opening	Travel min.	45°	45°	45°	45°
	Force min.	19 N	19 N	19 N	19 N

\*1 Reference value

**HIGHLY**

A21

Design, specifications are subject to change without notice.

## » Operating Characteristics

### Actuator Type EDR-□-□-27 Adjustable Roller Arm

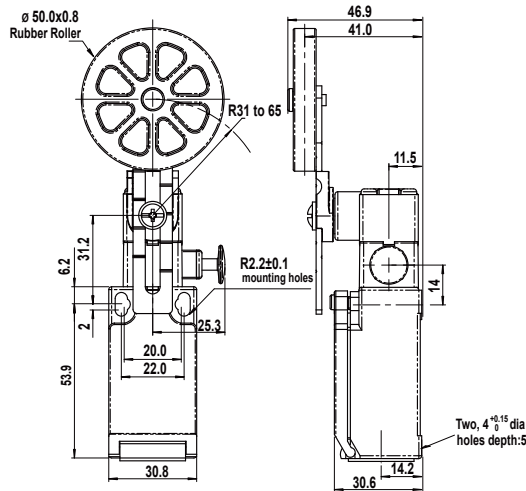

Operating characteristics	Model	EDR-□-1-27	EDR-□-3-27	EDR-□-2-27	EDR-□-6-27
		EDR-□-4-27		EDR-□-5-27	
Operating force	OF max.	5.2 N	4.5 N	5.2 N	4.5 N
Release force	RF min.	0.4 N	0.4 N	0.4 N	0.4 N
Pretravel	PT (NC)	25°~35°	23°~33°	25°~35°	18°~27°
	PT2 (NO)※1	(40°)	-	-	-
Overtravel	OT min.	40°	40°	40°	40°
Movement differential	MD max.	-	20°	-	14°
Total travel	TT※1	(80°)	(80°)	(80°)	(80°)
Positive Opening	Travel min.	45°	45°	45°	45°
	Force min.	19 N	19 N	19 N	19 N

\*1 Reference value

### Actuator Type EDR-□-□-31 Push Plunger

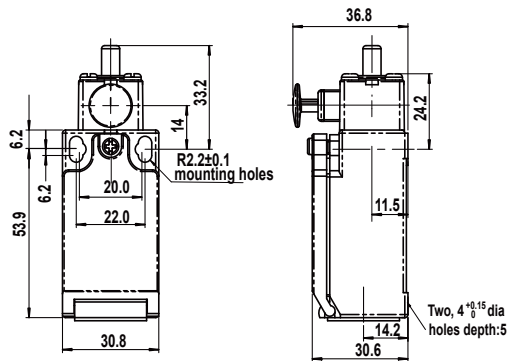

Operating characteristics	Model	EDR-□-1-31	EDR-□-3-31	EDR-□-2-31	EDR-□-6-31
		EDR-□-4-31		EDR-□-5-31	
Operating force	OF max.	7.3 N	6.8 N	7.5 N	6.5 N
Release force	RF min.	1.5 N	1.5 N	1.5 N	1.5 N
Pretravel	PT (NC) max	2.2 mm	2.2 mm	2.2 mm	2.2 mm
	PT2 (NO)※1	(3 mm)	-	-	-
Overtravel	OT min.	4 mm	4 mm	4 mm	4 mm
Movement differential	MD max.	-	1.5 mm	-	1 mm
Operating position	OP (mm)	31±0.5	31±0.5	31±0.5	31±0.5
Total travel	TT※1	(6 mm)	(6 mm)	(6 mm)	(6 mm)
Positive Opening	Travel min.	3.2 mm	3.2 mm	3.2 mm	3.2 mm
	Force min.	19 N	19 N	19 N	19 N

\*1 Reference value

### Actuator Type EDR-□-□-32 Roller Plunger

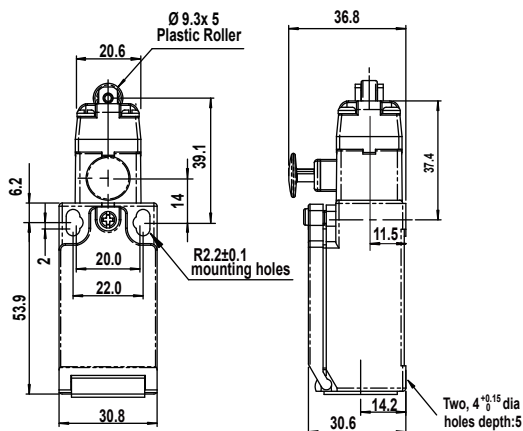

Operating characteristics	Model	EDR-□-1-32	EDR-□-3-32	EDR-□-2-32	EDR-□-6-32
		EDR-□-4-32		EDR-□-5-32	
Operating force	OF max.	7.3 N	6.8 N	7.5 N	6.5 N
Release force	RF min.	1.5 N	1.5 N	1.5 N	1.5 N
Pretravel	PT (NC) max	2.2 mm	2.2 mm	2.2 mm	2.2 mm
	PT2 (NO)※1	(3 mm)	-	-	-
Overtravel	OT min.	4 mm	4 mm	4 mm	4 mm
Movement differential	MD max.	-	1.5 mm	-	1 mm
Operating position	OP (mm)	26.9±0.8	26.9±0.8	26.9±0.8	26.9±0.8
Total travel	TT※1	(6 mm)	(6 mm)	(6 mm)	(6 mm)
Positive Opening	Travel min.	3.2 mm	3.2 mm	3.2 mm	3.2 mm
	Force min.	19 N	19 N	19 N	19 N

\*1 Reference value

**HIGHLY**

A22

Design, specifications are subject to change without notice.

**» Operating Characteristics**

**Actuator Type EDR-□-□-62 Roller Lever**

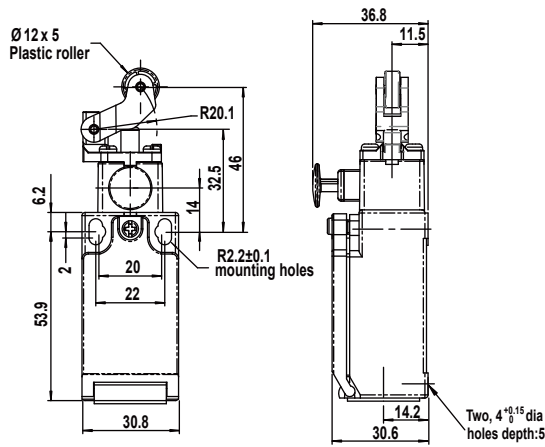

Operating characteristics	Model	EDR-□-1-62	EDR-□-3-62	EDR-□-2-62	EDR-□-6-62
		EDR-□-4-62	EDR-□-5-62		
Operating force	OF max.	5.3 N	4.8 N	5.3 N	5.0 N
Release force	RF min.	0.8 N	0.8 N	0.8 N	0.8 N
Pretravel	PT (NC) max.	3.3 mm	3.3 mm	3.3 mm	3.3 mm
	PT2 (NO)※1	(4.1 mm)	-	-	-
Overtravel	OT min.	5 mm	5 mm	5 mm	5 mm
Movement differential	MD max.	-	2.0 mm	-	1.5 mm
Operating position	OP (mm).	42.7±0.8	42.7±0.8	42.7±0.8	42.7±0.8
Total travel	TT※1	(9 mm)	(9 mm)	(9 mm)	(9 mm)
	Travel min.	5.7 mm	5.7 mm	5.7 mm	5.7 mm
Positive Opening	Force min.	19 N	19 N	19 N	19 N

\*1 Reference value

**Actuator Typ e EDR-□-□-63 One-Way Roller Arm Lever**

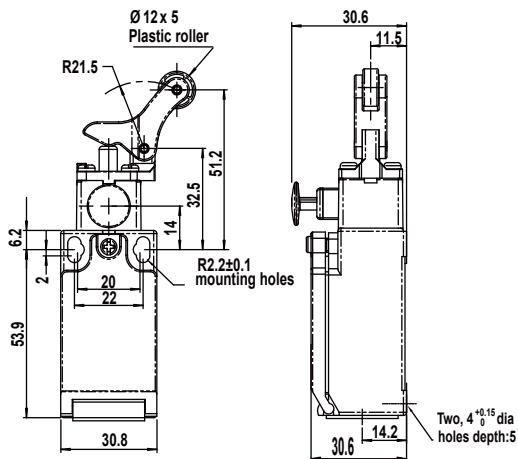

Operating characteristics	Model	EDR-□-1-63	EDR-□-3-63	EDR-□-2-63	EDR-□-6-63
		EDR-□-4-63	EDR-□-5-63		
Operating force	OF max.	6.4 N	5.8 N	7.0 N	5.0 N
Release force	RF min.	0.8 N	0.8 N	0.8 N	0.8 N
Pretravel	PT (NC) max.	4 mm	4 mm	4 mm	4 mm
	PT2 (NO)※1	(6.0 mm)	-	-	-
Overtravel	OT min.	5 mm	5 mm	5 mm	5 mm
Movement differential	MD max.	-	2.0 mm	-	1.5 mm
Operating position	OP (mm).	47.2±0.8	47.2±0.8	47.2±0.8	47.2±0.8
Total travel	TT※1	(9.8 mm)	(9.8 mm)	(9.8 mm)	(9.8 mm)
	Travel min.	4.6 mm	4.6 mm	4.6 mm	4.6 mm
Positive Opening	Force min.	19 N	19 N	19 N	19 N

\*1 Reference value

**» Switch Mounting**

- Using M4 mounting screws with plane washers or spring washers to secure a tight mounting. Tightening the screws with the torque of 0.5N to 0.7 Nm.
- Make sure that the dog contacts the actuator at a right angle. Applying a load to the switch actuator (roller) on a slant may result in deformation or damage of the actuator or rotary shaft.
- Operation of the switch should avoid bearing oblique force, as this may lead to structural damage to the switch.

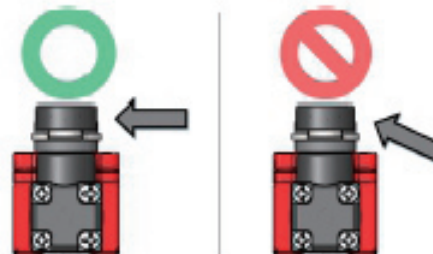
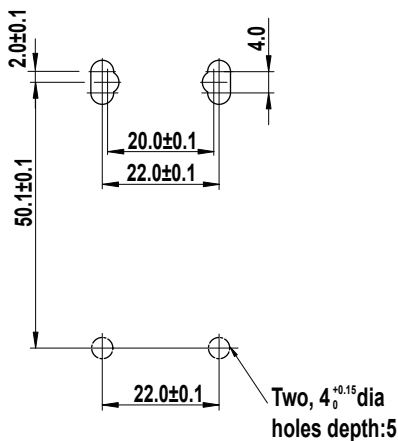

**HIGHLY**

A23

Design, specifications are subject to change without notice.