

» Description

The ED series safety limit switches conform to EN 50047 and have been developed to provide a range of options including plastic cases in various sizes, a choice of snap acting, slow break/make with 2 contact configurations and a choice of actuator heads.

The ED series offers the option of rotating the head in 90° increments before installation to allow ease of mounting.

Highly limit switches can be used in other applications other than guard doors, for example on moving machine beds, crane arms, lifts, elevators, etc.

Operation of these limit switches is achieved by the sliding action of the guard or other moving object deflecting the plunger or lever.

For safety applications it is important that upon actuation, the guard or other moving objects should not pass completely over the switch and allow the plunger or lever to return to its original position.

» Features

- Conforms to EN (TUV) standards corresponding to the CE marking
- Positive opening operation of NC (Normally Closed) contacts conforming to IEC /EN 60947-5-1
- Double insulation makes ground terminal unnecessary (Bears marking)
- Wide standard operating temperature range: -25° C to 80° C
- Full range of actuator heads and levers suitable for safety applications
- Sealing up to IP 67
- Wide switch variations, (Snap action and slow action basic switches)
- International conduit sizes



» Specifications

Electrical Characteristics		
Rating	TUV (EN60947-5-1), UKCA(BS EN60947-5-1) , CCC (GB 14048.5)	
	Utilization category	AC-15
	Rated operating current (Ie)	3A
	Rated operating voltage (Ue)	240V
	UL (UL508) AC-15 A600	
	Contact Type	1: 1NC/1NO Slow Action BBM
		2: 2NC Slow Action
		6: 1NC/1NO Snap Action Zb
	UL (UL508) AC-15 A300	
	Contact Type	4: 2NC/1NO Slow Action BBM
5: 3NC Slow Action		
UL (UL508) AC-15 B600		
Contact Type	3: 1NC/1NO Snap Action Za	

Electrical Characteristics	
Contact resistance	Initial value 25mΩ max.
Min Current	5VDC 5mA
Insulation Voltage	600V
Thermal Current (Ith)	10A
Insulation Resistance	100MΩ Min (DC 500V)
Protection Against Electric Shock	Class II (double insulation).
Dielectric Strength	2,500V 50/60Hz for 1 minute.
Rated Frequency	50/60 Hz.
Pollution Degree	3

Mechanical Characteristics	
Electrical durability	150,000 Cycles Min.
Mechanical durability	10,000,000 Cycles Min.
Vibration durability	IEC 68-2-6, 10-55Hz±1 HZ, Excursion: 0.35mm, 1 octave/min.
Shock durability	300 m/s ² min.
Max Switching Speed	250mm/s.

IEC 60947-5-1/EN 60947-5-1									
Designation & Utilization Category		Rated operational current Ie (A) at rated operational voltage Ue						VA rating	
		120V	240V	380V	480V	500V	600V	Make	Break
AC-15	A600	6	3	1.9	1.5	1.4	1.2	7200	720
AC-15	A300	6	3	-	-	-	-	7200	720
AC-15	B600	3	1.5	-	-	-	-	3600	360

Climatic Characteristics	
Degree of Protection	IP67
Operating Humidity	95% max. (for 5°C to 40°C)
Operating Temperature	-25°C ~ +80°C

HIGHLY

A7

Design, specifications are subject to change without notice.

» Structure Description

Metal Lever Setting

Grooves which engage the lever every 18° are cut in the operation indicator disk to prevent the lever from slipping against the rotary shaft.

Cover

The cover, with a hinge on its lower part, can be opened by removing the screw of the cover, which ensures ease of maintenance and wiring.

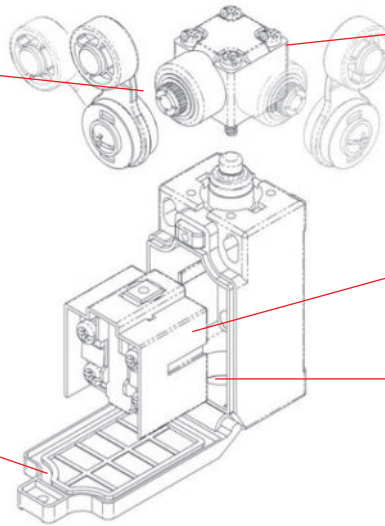

Hand

With roller lever models, the direction of the switch head can be varied to any of the four directions by loosening the roller lever switch screws at the four corners of the head.

Contact Block

Wide switch variations.
 Snap-action: 1NC/1NO
 Slow-action: 1NC/1NO, 2NC, 2NC/1NO, 3NC

Conduit

Wide switch variations.
 PG13.5 PG11
 M16 M20
 1/2-14NPT

» Product Selection

ED-□-□-□

1 2 3

1.THREAD DIMENSION OF LEAD EXIT

1: PG13.5(S)

2: 1/2NPT(C)

4: PG11(O)

5: M16(C)

6: M20(O)

7: Connector(C)

*(s):standard (o):option (c): customization

M12 Connector pin arrangement

①: 11
 ②: 21/23
 ③: 12
 ④: 22/24

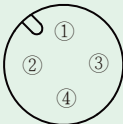

OPERATION DIAGRAMS

3.HEAD AND ACTUATOR

20: Roller arm type

21: Adjustable roller arm type (standard roller)

22: Adjustable roller arm type (Long arm type)

24: Thermoplastic end flexible rod type

241: Cat whisker type

242: Wobble stick type

31: Push plunger type

25: Rod lever type

27: Adjustable roller arm type (Rubber roller)

31: Push plunger type

32: Roller plunger type

62: Roller lever type

63: One-Way roller arm lever type

2.CONTACT TYPES

1: 1NC/1NO SLOW ACTION (BBM)(S)

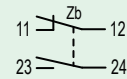

2: 2NC SLOW ACTION(O)

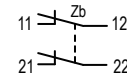

3: 1NC/1NO SNAP ACTION(C)

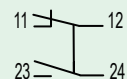

4: 2NC/1NO SLOW ACTION

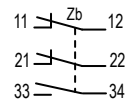

5: 3NC SLOW ACTION

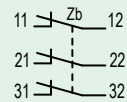

6: 1NC/1NO SNAP ACTION(Zb)(C)

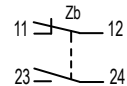

» Operating Characteristics

Actuator Type ED-□-□-20 Roller Arm

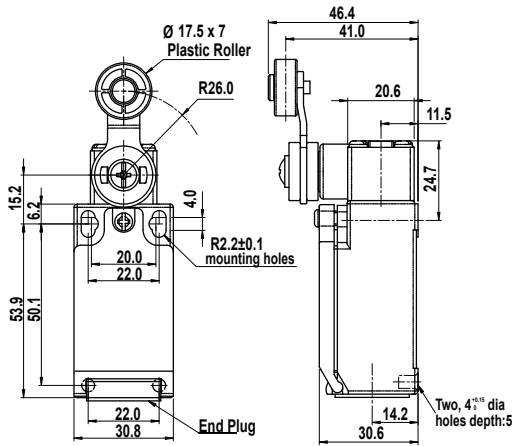

Operating characteristics	Model	ED-□-1-20	ED-□-3-20	ED-□-2-20	ED-□-6-20
		ED-□-4-20	ED-□-5-20	ED-□-5-20	ED-□-6-20
Operating force	OF max.	6.5 N	5.3 N	6.5 N	5.0 N
Release force	RF min.	0.5 N	0.5 N	0.5 N	0.5 N
Pretravel	PT (NC)	25°~35°	23°~33°	25°~35°	18°~27°
	PT2 (NO)	(40°)	-	-	-
Overtravel	OT min.	40°	40°	40°	40°
Movement differential	MD max.	-	20°	-	14°
Total travel	TT※1	(80°)	(80°)	(80°)	(80°)
Positive Opening	Travel min.	45°	45°	45°	45°
	Force min.	19 N	19 N	19 N	19 N

*1 Reference value

Actuator Type ED-□-□-21 Adjustable Roller

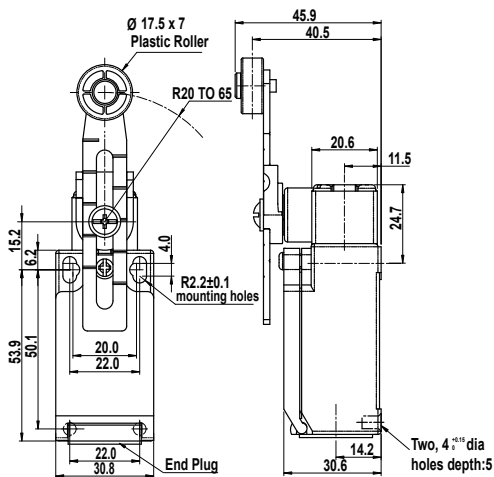

Operating characteristics	Model	ED-□-1-21	ED-□-3-21	ED-□-2-21	ED-□-6-21
		ED-□-4-21	ED-□-5-21	ED-□-5-21	ED-□-6-21
Operating force	OF max.	5.2 N	4.5 N	5.2 N	4.5 N
Release force	RF min.	0.4 N	0.4 N	0.4 N	0.4 N
Pretravel	PT (NC)	25°~35°	23°~33°	25°~35°	18°~27°
	PT2 (NO)※1	(40°)	-	-	-
Overtravel	OT min.	40°	40°	40°	40°
Movement differential	MD max.	-	20°	-	14°
Total travel	TT※1	(80°)	(80°)	(80°)	(80°)
Positive Opening	Travel min.	45°	45°	45°	45°
	Force min.	19 N	19 N	19 N	19 N

*1 Reference value

Actuator Type ED-□-□-25 Rod Lever

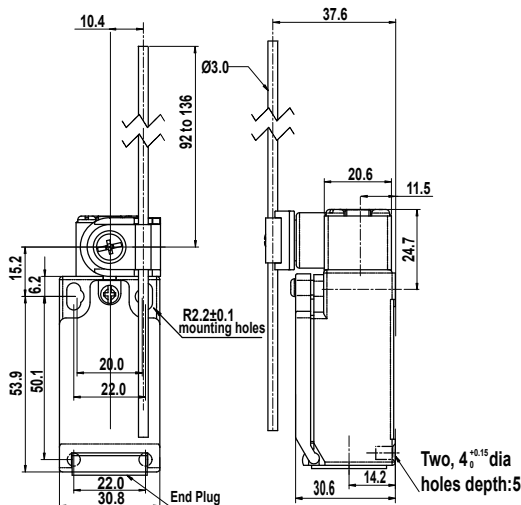

Operating characteristics	Model	ED-□-1-25	ED-□-3-25	ED-□-2-25	ED-□-6-25
		ED-□-4-25	ED-□-5-25	ED-□-5-25	ED-□-6-25
Operating force	OF max.	1.8 N	1.8 N	1.8 N	1.8 N
Release force	RF min.	0.5 N	0.5 N	0.5 N	0.5 N
Pretravel	PT (NC)	25°~35°	23°~33°	25°~35°	18°~27°
	PT2 (NO)※1	(40°)	-	-	-
Overtravel	OT min.	40°	40°	40°	40°
Movement differential	MD max.	-	20°	-	14°
Total travel	TT※1	(80°)	(80°)	(80°)	(80°)
Positive Opening	Travel min.	45°	45°	45°	45°
	Force min.	19 N	19 N	19 N	19 N

*1 Reference value

HIGHLY

A9

Design, specifications are subject to change without notice.

» Operating Characteristics

Actuator Type ED-□-□-24 Thermoplastic End Flexible Road

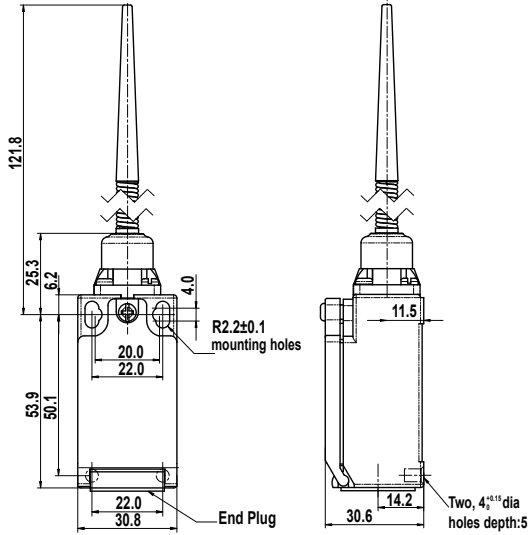

Model		ED-□-2-24	ED-□-3-24	ED-□-5-24	ED-□-6-24
Operating characteristics					
Operating force	OF max.	6.5 N	5.3 N	6.5 N	5.0 N
Pretravel	PT max.	16°	16°	16°	16°

Actuator Type ED-□-□-241 Cat Whisker

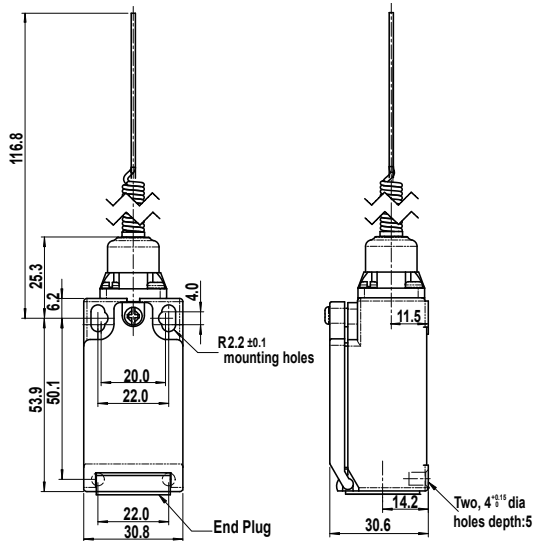

Model		ED-□-2-241	ED-□-3-241	ED-□-5-241	ED-□-6-241
Operating characteristics					
Operating force	OF max.	6.5 N	5.3 N	6.5 N	5.3 N
Pretravel	PT max.	16°	16°	16°	16°

Actuator Type ED-□-□-242 Wobble Stick

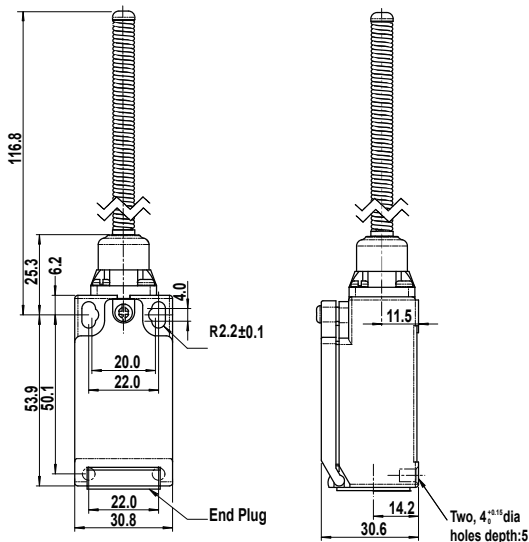

Model		ED-□-2-242	ED-□-3-242	ED-□-5-242	ED-□-6-242
Operating characteristics					
Operating force	OF max.	6.5 N	5.3 N	6.5 N	5.3 N
Pretravel	PT max.	16°	16°	16°	16°

HIGHLY

A10

Design, specifications are subject to change without notice.

» Operating Characteristics

Actuator Type ED-□-□-27 Adjustable Roller Arm

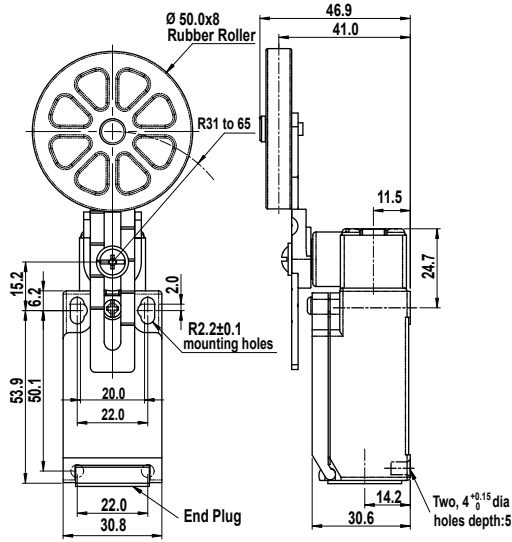

Operating characteristics	Model	ED-□-1-27	ED-□-3-27	ED-□-2-27	ED-□-6-27
		ED-□-4-27		ED-□-5-27	
Operating force	OF max.	5.2 N	4.5 N	5.2 N	4.5 N
Release force	RF min.	0.4 N	0.4 N	0.4 N	0.4 N
Pretravel	PT (NC)	25°~35°	23°~33°	25°~35°	18°~27°
	PT2 (NO)※1	(40°)	-	-	-
Overtravel	OT min.	40°	40°	40°	40°
Movement differential	MD max.	-	20°	-	14°
Total travel	TT※1	(80°)	(80°)	(80°)	(80°)
Positive Opening	Travel min.	45°	45°	45°	45°
	Force min.	19 N	19 N	19 N	19 N

*1 Reference value

Actuator Type ED-□-□-31 Push Plunger

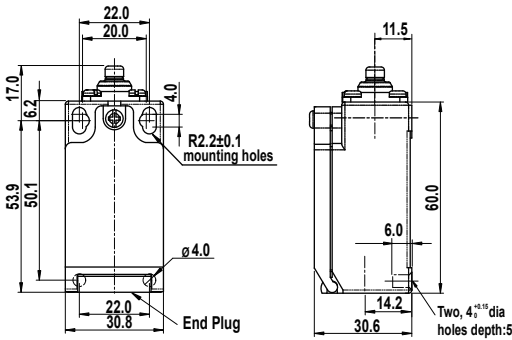

Operating characteristics	Model	ED-□-1-31	ED-□-3-31	ED-□-2-31	ED-□-6-31
		ED-□-4-31		ED-□-5-31	
Operating force	OF max.	7.3 N	6.8 N	7.5 N	6.5 N
Release force	RF min.	1.5 N	1.5 N	1.5 N	1.5 N
Pretravel	PT (NC) max.	2.2 mm	2.2 mm	2.2 mm	2.2 mm
	PT2 (NO)※1	(3 mm)	-	-	-
Overtravel	OT min.	4 mm	4 mm	4 mm	4 mm
Movement differential	MD max.	-	1.5 mm	-	1 mm
Operating position	OP (mm)	15.3±0.5	15.3±0.5	15.3±0.5	15.3±0.5
Total travel	TT※1	(6 mm)	(6 mm)	(6 mm)	(6 mm)
Positive Opening	Travel min.	3.2 mm	3.2 mm	3.2 mm	3.2 mm
	Force min.	19 N	19 N	19 N	19 N

*1 Reference value

Actuator Type ED-□-□-32 Roller Plunger

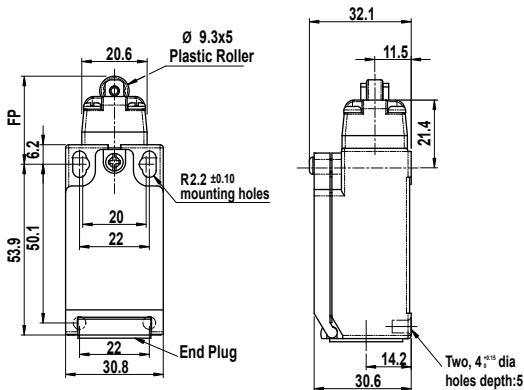

Operating characteristics	Model	ED-□-1-32	ED-□-3-32	ED-□-2-32	ED-□-6-32
		ED-□-4-32		ED-□-5-32	
Operating force	OF max.	7.3 N	6.8 N	7.5 N	6.5 N
Release force	RF min.	1.5 N	1.5 N	1.5 N	1.5 N
Pretravel	PT (NC) max.	2.2 mm	2.2 mm	2.2 mm	2.2 mm
	PT2 (NO)※1	(3 mm)	-	-	-
Overtravel	OT min.	4 mm	4 mm	4 mm	4 mm
Movement differential	MD max.	-	1.5 mm	-	1 mm
Operating position	OP (mm)	25.6±0.8	25.6±0.8	25.6±0.8	25.6±0.8
Total travel	TT※1	(6 mm)	(6 mm)	(6 mm)	(6 mm)
Positive Opening	Travel min.	3.2 mm	3.2 mm	3.2 mm	3.2 mm
	Force min.	19 N	19 N	19 N	19 N

*1 Reference value

HIGHLY

A11

Design, specifications are subject to change without notice.

» Operating Characteristics

Actuator Type ED-□-□-62 Roller Lever

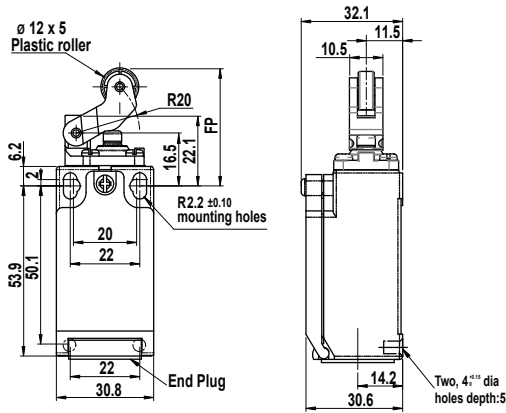

Operating characteristics	Model	ED-□-1-62	ED-□-3-62	ED-□-2-62	ED-□-6-62
		ED-□-4-62	ED-□-5-62	ED-□-6-62	
Operating force	OF max.	5.3 N	4.8 N	5.3 N	5.0 N
Release force	RF min.	0.8 N	0.8 N	0.8 N	0.8 N
Pretravel	PT (NC) max.	3.3 mm	3.3 mm	3.3 mm	3.3 mm
	PT2 (NO)※1	(4.1 mm)	-	-	-
Overtravel	OT min.	5 mm	5 mm	5 mm	mm
Movement differential	MD max.	-	2.0 mm	-	1.5 mm
Operating position	OP (mm)	33.5±0.8	33.5±0.8	33.5±0.8	33.5±0.8
Total travel	TT※1	(9 mm)	(9 mm)	(9 mm)	(9 mm)
	Travel min.	5.7 mm	5.7 mm	5.7 mm	5.7 mm
Positive Opening	Force min.	19 N	19 N	19 N	19 N

*1 Reference value

Actuator Type ED-□-□-63 One-Way Roller Arm Lever

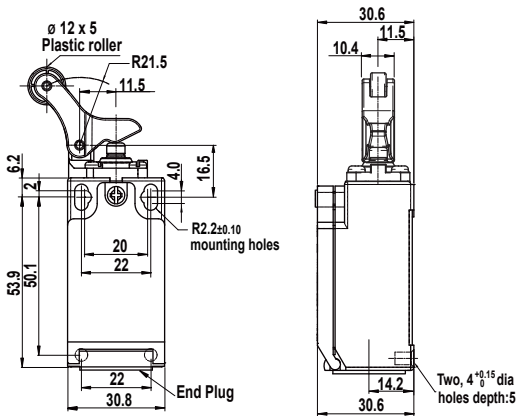

Operating characteristics	Model	ED-□-1-63	ED-□-3-63	ED-□-2-63	ED-□-6-63
		ED-□-4-63	ED-□-5-63	ED-□-6-63	
Operating force	OF max.	6.4 N	5.8 N	7.0 N	5.0 N
Release force	RF min.	0.8 N	0.8 N	0.8 N	0.8 N
Pretravel	PT (NC) max.	4 mm	4 mm	4 mm	4 mm
	PT2 (NO)※1	(6.0 mm)	-	-	-
Overtravel	OT min.	5 mm	5 mm	5 mm	5 mm
Movement differential	MD max.	-	2.0 mm	-	1.5 mm
Operating position	OP (mm)	24.7±0.8	24.7±0.8	24.7±0.8	24.7±0.8
Total travel	TT※1	(9.8 mm)	(9.8 mm)	(9.8 mm)	(9.8 mm)
	Travel min.	4.6 mm	4.6 mm	4.6 mm	4.6 mm
Positive Opening	Force min.	19 N	19 N	19 N	19 N

*1 Reference value

Actuator Type ED-□-□-22 Adjustable Roller Arm Long Arm

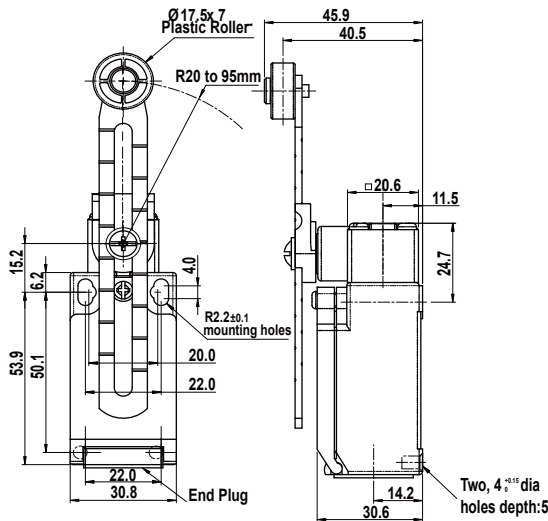

Operating characteristics	Model	ED-□-1-22	ED-□-3-22	ED-□-2-22	ED-□-6-22
		ED-□-4-22	ED-□-5-22	ED-□-6-22	
Operating force	OF max.	5.2 N	4.5 N	5.2 N	4.5 N
Release force	RF min.	0.4 N	0.4 N	0.4 N	0.4 N
Pretravel	PT (NC)	25°~35°	23°~33°	25°~35°	18°~27°
	PT2 (NO)※1	(40°)	-	-	-
Overtravel	OT min.	40°	40°	40°	40°
Movement differential	MD max.	-	20°	-	14°
Total travel	TT※1	(80°)	(80°)	(80°)	(80°)
Positive Opening	Travel min.	45°	45°	45°	45°
	Force min.	19 N	19 N	19 N	19 N

*1 Reference value

HIGHLY

A12

Design, specifications are subject to change without notice.

»» Precautions for Safe Use

1. Do not use the Switch submerged in oil or water, or in locations continuously subject to splashes of oil or water. Doing so may result in oil or water entering the Switch interior.
(The IP67 degree of protection specification for the Switch refers to water penetration while the Switch is submerged in water for a specified period of time.)
2. Always attach the cover after completing wiring and before using the Switch. Also, do not turn ON the Switch with the cover open. Doing so may result in electric shock performance.
3. Do not switch circuits for two or more standard loads (250 VAC, 3A). Doing so may adversely affect insulation

»» Precautions for Correct Use

1. The Switch contacts can be used with either standard loads or micro loads. Once the contacts have been used to switch a load, however, they cannot be used to switch smaller loads. The contact surfaces will become rough once they have been used and contact reliability for smaller loads may be reduced.
2. Appropriate Tightening Torque Tighten each of the screws to the specified torque. Loose screws may result in malfunction of the Switch within a short time.

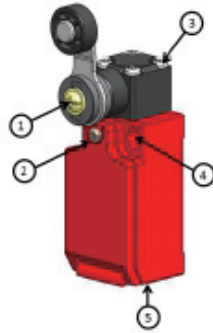

#	Positioning description	Torque
1	Lever mounting screw	1.6 to 1.8 Nm
2	Cover mounting screw	0.5 to 0.6 Nm
3	Head mounting screw	0.5 to 0.6 Nm
4	Body mounting screw	0.5 to 0.7 Nm
5	Conduit Thread	1.8 to 2.2 Nm

»» Switch Mounting

1. Using M4 mounting screws with flat washers or spring washers to secure a tight mounting. Tightening the screws with the torque of 0.5N to 0.7 Nm.
2. Make sure that the dog contacts the actuator at a right angle. Applying a load to the switch actuator (roller) on a slant may result in deformation or damage of the actuator or rotary shaft.
3. Operation of the switch should avoid bearing oblique force, as this may lead to structural damage to the switch.

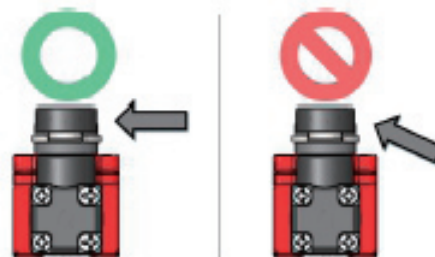
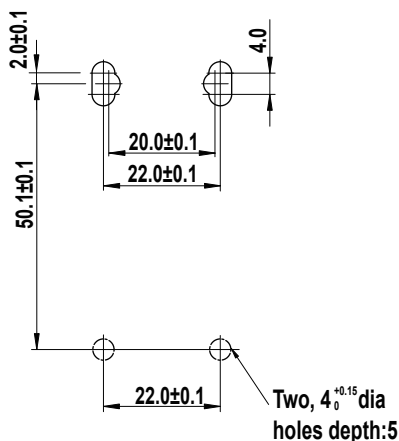

»Operating Stroke Setting

- 1.Setting an operating dog in the direction where the actuator moves and detaching the dog from the actuator completely when the switch is at the free position (FP).
- 2.70 to 100% of the overtravel(OT) is appropriate for the switch stroke setting.
- 3.Avoiding an impact operation as much as possible as it can cause life deterioration.

»Wiring

- 1.Wiring the switch by insulated tube M3.5, do not push excessive force to case or cover to avoid damage on switch.
- 2.Offering appropriate wire length to avoid squeeze force to cover or contact block, can be free of switch malfunction or liquid ingress issue.

»Conduit Opening

- 1.Be sure to use the suggested connector and secure it with the specified screws tightened to the specified torque. The case of product may be damaged if an excessive tightening torque is applied.
- 2.Be sure to use cable with an appropriate diameter to match with connector.

»Storage Environment

- 1.When storing the Switch, make sure that the location is free of corrosive gas, heavy dust and keep away from high temperature or humidity.
- 2.Be sure to inspect the Switch before use if it's stored for more than 6 months.

»ED24 / ED241 / ED242

- 1.these 3 models can not carry with slow action type of contact block.
- 2.concerning to structure on lever, we strongly suggest to regard these 3 models as general purpose limit switch rather than safety limit switch.

»Operating Charactertics

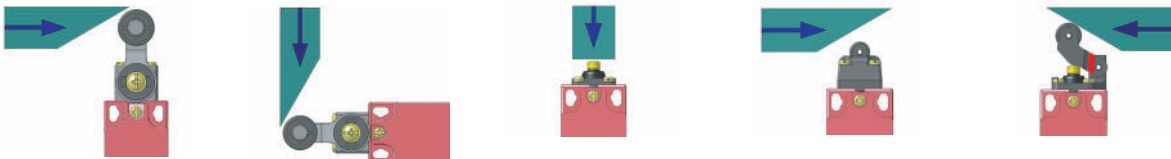

»Typical Applications

